

1

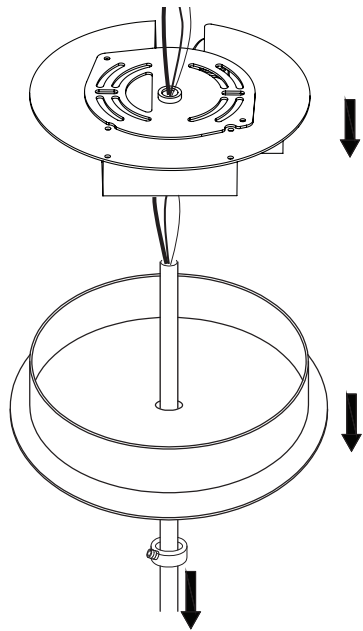

3

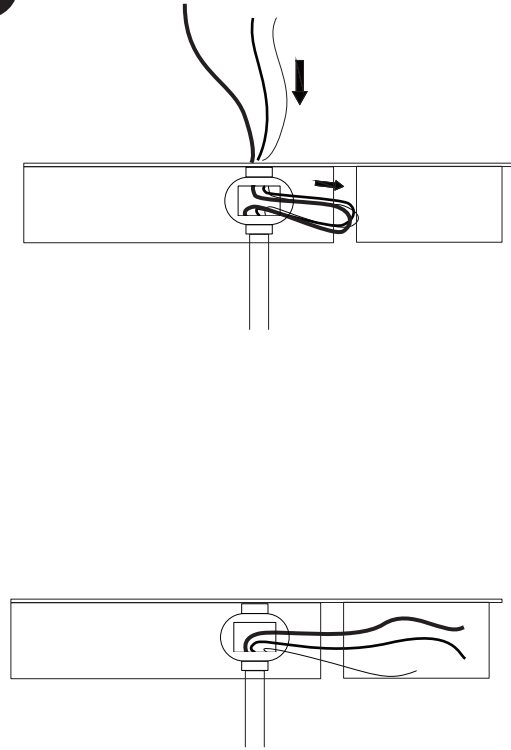

NEVER HOLD THE FIXTURE ON THE SIDE. IT WILL AUTOMATICALLY BREAK THE STEM
 NE JAMAIS TENIR LE LUMINAIRE SUR LE CÔTÉ. CECI VA AUTOMATIQUEMENT BRISER LA TIGE

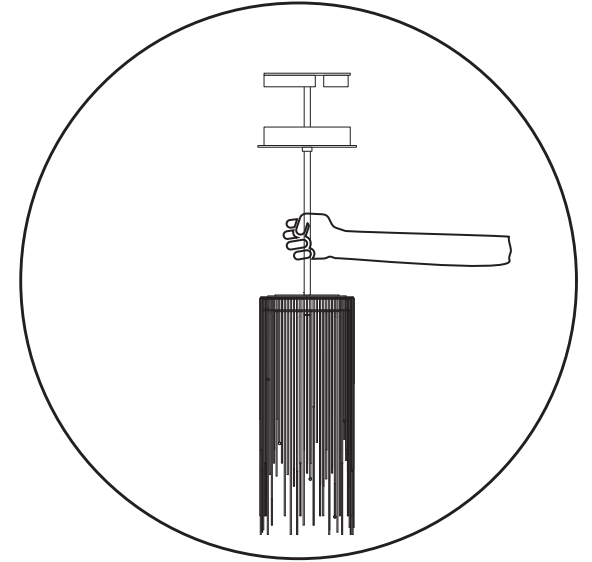
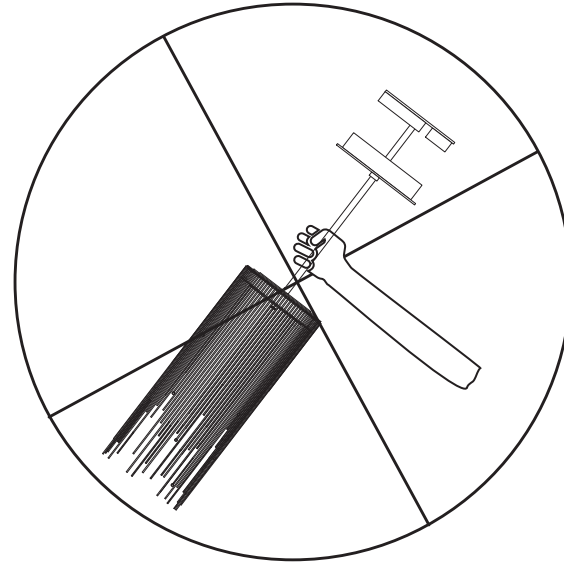

2



Ensure it is fully screwed. Failure to do so may compromise safety.
 Assurez-vous ce soit complètement vissé. Le non-respect de cela peut compromettre la sécurité.

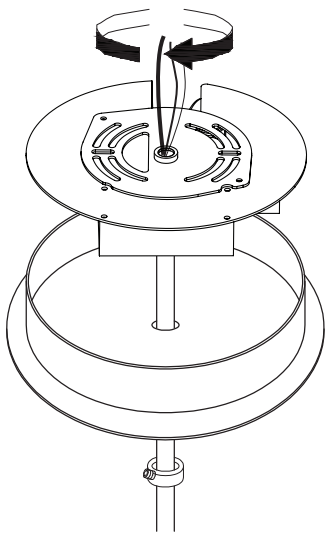

twentieth

sales@twentieth.net

323.904.1200

www.twentieth.gallery

4

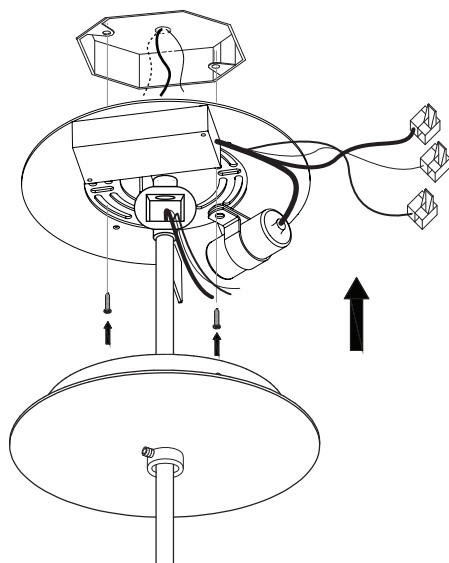

6

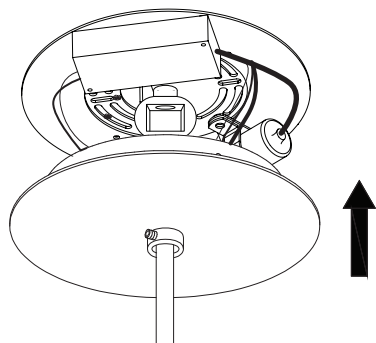

5

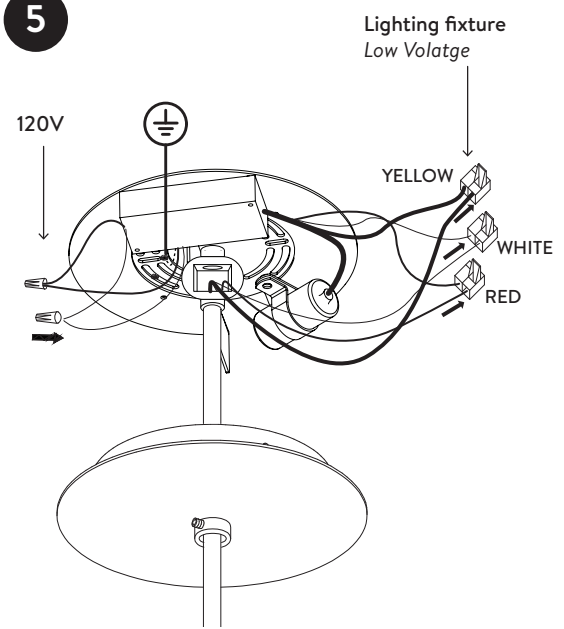

7

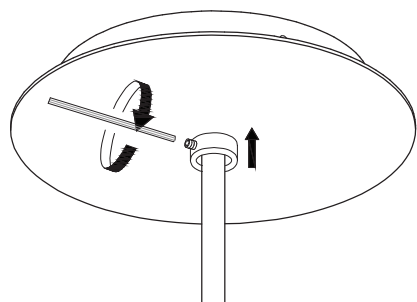

8

CAREFULLY UNPACK THE FIXTURE
DÉBALLER SOIGNEUSEMENT LE LUMINAIRE



OTÉRO XS-01

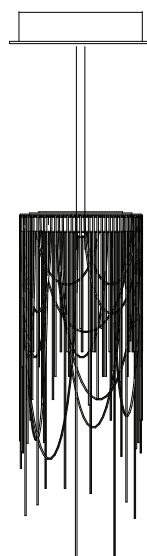

OTÉRO XS-02

LAROSE GUYON

CAUTION / ATTENTION



- Before starting, turn off power at main circuit panel / Couper l'alimentation avant à l'installation.
- Use appropriate screws and anchors / Utiliser les vis et les ancrages appropriés
- Wear gloves when handling lamp and handle materials with care / Portez des gants lors de la manipulation de la lampe et manipulez les matériaux avec précaution.



NOTES

LAROSE GUYON recommends that the lighting fixtures be installed by a professional. LAROSE GUYON is not responsible or liable under any circumstances for misfortunes and/or accidents that may occur due to the installation of their products. / LAROSE GUYON recommande fortement l'utilisation des services d'un professionnel pour l'accrochage et l'installation de tous les luminaires. LAROSE GUYON n'est pas responsable, en aucun cas, des accidents dus à l'installation de leurs produits.

ASSEMBLY / ASSEMBLAGE OTÉRO-XS