

CHRISTOPHER BOOTS

# CRUX MONO

CRUX explores the natural geometries of the five stars that form the Southern Cross - one of the most recognisable constellations in the southern sky.

CRUX MONO tells the story of a solitary star, radiating a gentle glow through organically shaped glass, akin to a celestial beacon.

*Crux Mono III in Aged Brass*



---

twentieth

sales@twentieth.net 323.904.1200 www.twentieth.net

# CRUX MONO

(I)

SPECIFICATIONS	OPTIONS	ADDITIONAL INFORMATION	WARRANTY
<p>ORDERING CODE CRX.M.I</p> <p>LAMP 12V LED WW 2700K</p> <p>LUMENS 1700 LM</p> <p>VOLTAGE 12V DC</p> <p>WATTS 4W</p> <p>WEIGHT Approx. 6kg <i>(not including canopy)</i></p> <p>INCLUSIONS Power Supply Unit x 30W</p> <p>EXCLUSIONS User Interface, Dimmer Unit</p>	<p>FINISHES</p> <p>AB Aged Brass BB Brushed Brass HRB Hand Rubbed Brass DB Dark Bronze MP Mottled Patina</p> <p>SUSPENSION Vertical Rod</p> <p>CANOPY</p> <p>R-80-FM* Round 80 Flush R-125-FM* Round 125 Flush R-300-FM† Round 300 Flush R-125-SM* Round 125 Surface R-300-SM† Round 300 Surface * Remote Power Supply † Integral Power Supply <i>Refer to canopy specification guide</i></p>	<ul style="list-style-type: none"> <li>Crux Mono is a solid fixture that will require very little maintenance over the years. If your Crux is treated with care, it will shine brightly for many years to come.</li> <li>Glass is hand blown by artisans and each piece will have a unique variation of size, shape, and clarity.</li> <li>Contact us for custom variations.</li> <li>Installation should only be undertaken by a qualified professional.</li> </ul>	<ul style="list-style-type: none"> <li>5 Years Fixture</li> <li>5 Years Power Supply Unit</li> <li>5 Years LED</li> </ul>
	<p><i>Fig 1. – Front view</i></p>	<p><i>Fig 2. – Top view</i></p>	

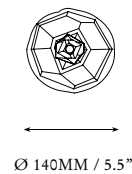
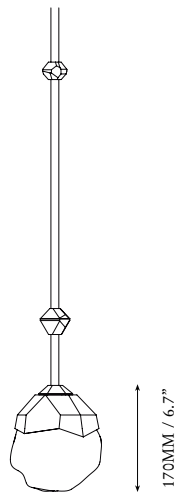

# CRUX MONO

(II)

SPECIFICATIONS	OPTIONS	ADDITIONAL INFORMATION	WARRANTY
<p>ORDERING CODE CRX.M.II</p> <p>LAMP 12V LED WW 2700K</p> <p>LUMENS 1700 LM</p> <p>VOLTAGE 12V DC</p> <p>WATTS 4W</p> <p>WEIGHT Approx. 7kg <i>(not including canopy)</i></p> <p>INCLUSIONS Power Supply Unit x 30W</p> <p>EXCLUSIONS User Interface, Dimmer Unit</p>	<p>FINISHES</p> <p>AB Aged Brass BB Brushed Brass HRB Hand Rubbed Brass DB Dark Bronze MP Mottled Patina</p> <p>SUSPENSION Vertical Rod</p> <p>CANOPY</p> <p>R-80-FM* Round 80 Flush R-125-FM* Round 125 Flush R-300-FM† Round 300 Flush R-125-SM* Round 125 Surface R-300-SM† Round 300 Surface * Remote Power Supply † Integral Power Supply <i>Refer to canopy specification guide</i></p>	<ul style="list-style-type: none"> <li>Crux Mono is a solid fixture that will require very little maintenance over the years. If your Crux is treated with care, it will shine brightly for many years to come.</li> <li>Glass is hand blown by artisans and each piece will have a unique variation of size, shape, and clarity.</li> <li>Contact us for custom variations.</li> <li>Installation should only be undertaken by a qualified professional.</li> </ul>	<ul style="list-style-type: none"> <li>5 Years Fixture</li> <li>5 Years Power Supply Unit</li> <li>5 Years LED</li> </ul>
<p>Fig 1. – Front view</p>		<p>Fig 2. – Top view</p>	

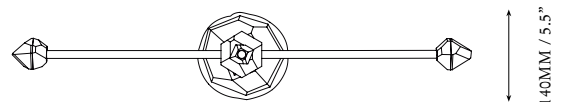
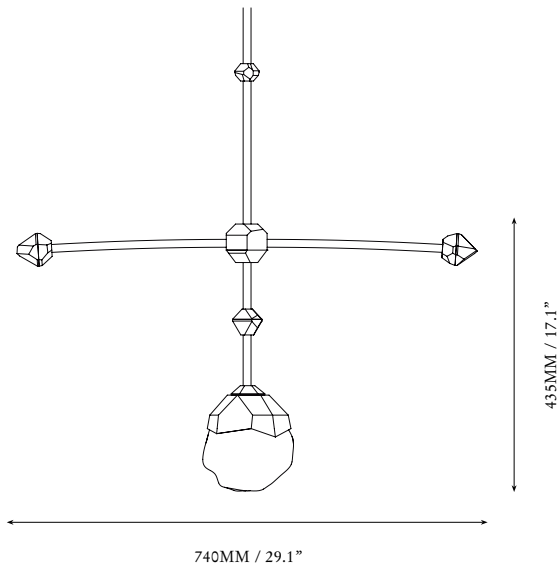
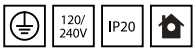

# CRUX MONO

## (III)

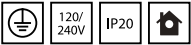
SPECIFICATIONS	OPTIONS	ADDITIONAL INFORMATION	WARRANTY
<p>ORDERING CODE CRX.M.III</p> <p>LAMP 12V LED WW 2700K</p> <p>LUMENS 1700 LM</p> <p>VOLTAGE 12V DC</p> <p>WATTS 4W</p> <p>WEIGHT Approx. 8kg <i>(not including canopy)</i></p> <p>INCLUSIONS Power Supply Unit x 30W</p> <p>EXCLUSIONS User Interface, Dimmer Unit</p>	<p>FINISHES</p> <p>AB Aged Brass</p> <p>BB Brushed Brass</p> <p>HRB Hand Rubbed Brass</p> <p>DB Dark Bronze</p> <p>MP Mottled Patina</p> <p>SUSPENSION Vertical Rod</p> <p>CANOPY</p> <p>R-80-FM* Round 80 Flush</p> <p>R-125-FM* Round 125 Flush</p> <p>R-300-FM† Round 300 Flush</p> <p>R-125-SM* Round 125 Surface</p> <p>R-300-SM† Round 300 Surface</p> <p>* Remote Power Supply</p> <p>† Integral Power Supply</p> <p><i>Refer to canopy specification guide</i></p>	<ul style="list-style-type: none"> <li>Crux Mono is a solid fixture that will require very little maintenance over the years. If your Crux is treated with care, it will shine brightly for many years to come.</li> <li>Glass is hand blown by artisans and each piece will have a unique variation of size, shape, and clarity.</li> <li>Contact us for custom variations.</li> <li>Installation should only be undertaken by a qualified professional.</li> </ul>	<ul style="list-style-type: none"> <li>5 Years Fixture</li> <li>5 Years Power Supply Unit</li> <li>5 Years LED</li> </ul>
		<p><i>Fig 1. – Front view</i></p>	<p><i>Fig 2. – Top view</i></p>

