

PETRA II 900, 1200, 1500, 1800, 2100, 2400

PENDANT ONLY

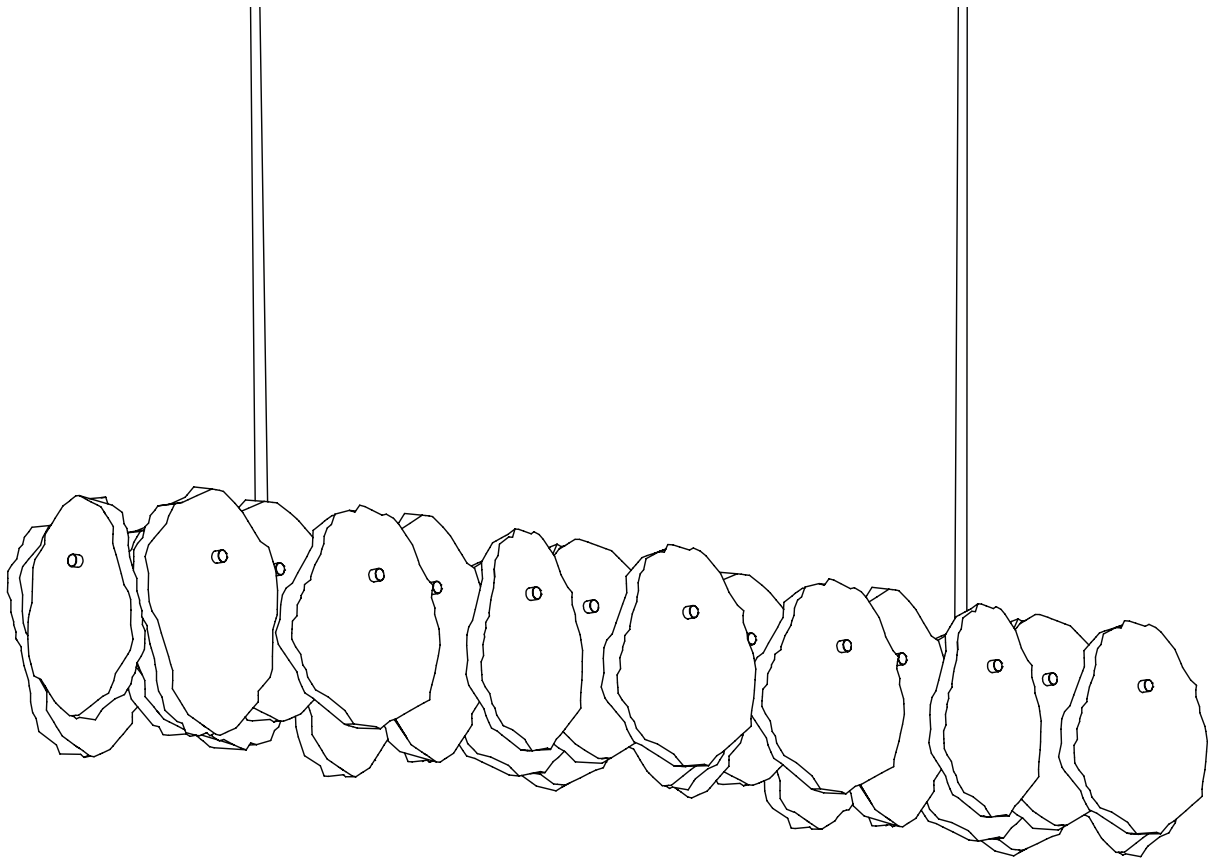



**WARNING:
SHOCK HAZARD**

May result in serious injury or death.
ENSURE POWER IS OFF before commencing any work.



**WARNING:
ELECTRICAL**

ALL ELECTRICAL connections must be made by a qualified electrician in accordance with the regulations and codes governing the area for which the CHRISTOPHER BOOTS Fixture is intended to be installed in. Failure to do so may result in serious harm or damage to property and life, at the owner’s liability and expense.
CHRISTOPHER BOOTS will not be held liable for any damage caused from installation.



**WARNING:
STRUCTURAL**

Ensure that the substrate is securely installed and is in accordance with local building regulations. Failure to do so may potentially result in serious harm or damage of property, at the owner’s liability and expense.
CHRISTOPHER BOOTS will not be held liable for any damage caused from installation.

TECHNICAL INFORMATION									
MODEL	MAX WATTAGE	FIXTURE VOLTAGE (CV)	LAMP TYPE	POWER SUPPLY INPUT VOLTAGE (V AC)	POWER SUPPLY WATTAGE (W)	POWER SUPPLY INPUT CURRENT (typ.)	POWER SUPPLY POWER FACTOR (typ.)	FIXTURE WEIGHT (KG)	EARTH IN CANOPY
PET.2.900	15	24	LED STRIP	100-120 @ 60Hz	60	0.8A/115VAC	PF≥0.97/115VAC	31	YES
				220-240 @ 50Hz		0.4A/230VAC	PF≥0.95/230VAC		
PET.2.1200	21	24	LED STRIP	100-120 @ 60Hz	60	0.8A/115VAC	PF≥0.97/115VAC	39	YES
				220-240 @ 50Hz		0.4A/230VAC	PF≥0.95/230VAC		
PET.2.1500	27	24	LED STRIP	100-120 @ 60Hz	60	0.8A/115VAC	PF≥0.97/115VAC	47	YES
				220-240 @ 50Hz		0.4A/230VAC	PF≥0.95/230VAC		
PET.2.1800	33	24	LED STRIP	100-120 @ 60Hz	60	0.8A/115VAC	PF≥0.97/115VAC	54	YES
				220-240 @ 50Hz		0.4A/230VAC	PF≥0.95/230VAC		
PET.2.2100	38	24	LED STRIP	100-120 @ 60Hz	60	0.8A/115VAC	PF≥0.97/115VAC	62	YES
				220-240 @ 50Hz		0.4A/230VAC	PF≥0.95/230VAC		
PET.2.2400	44	24	LED STRIP	100-120 @ 60Hz	60	0.8A/115VAC	PF≥0.97/115VAC	70	YES
				220-240 @ 50Hz		0.4A/230VAC	PF≥0.95/230VAC		

- 1 Wearing gloves, unpack the PETRA II fixture.
DO NOT remove calico wrapping until installation is complete.

- 2 Thread the power cable through one for the SUSPENSION RODS then secure the SUSPENSION RODS to the fixture frame by fastening them to the ALLTHREAD.

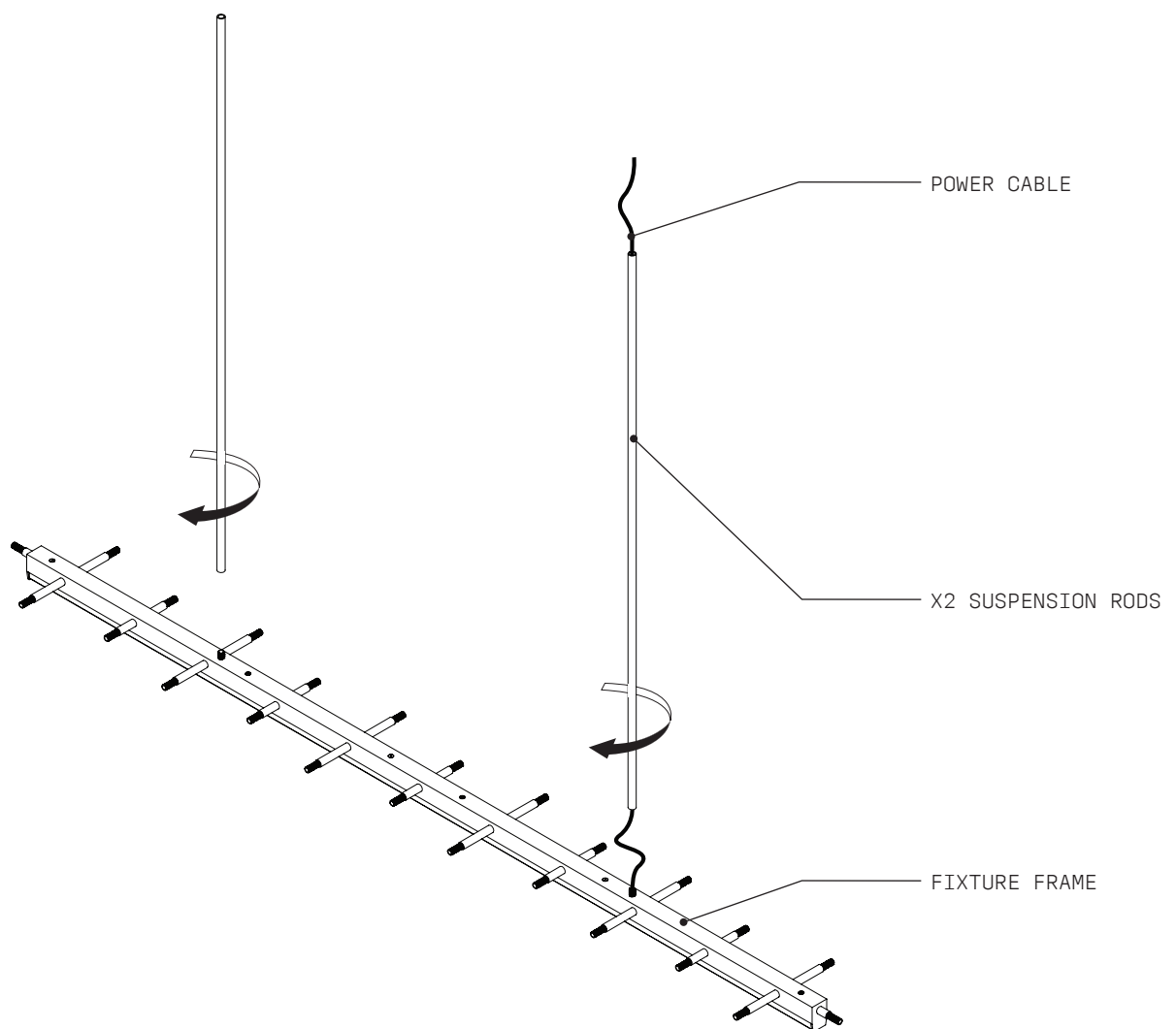

3 Refer to CANOPY INSTALLATION GUIDE to proceed.

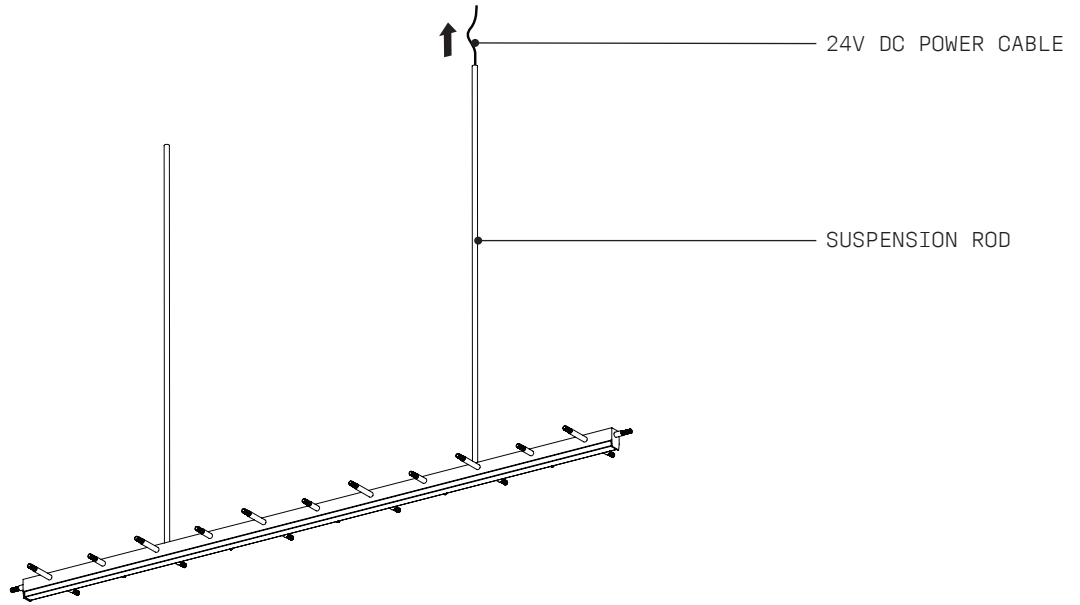

4 Once the fixture is suspended and secure, unwrap the quartz slices and begin to place them on to the ALLTHREAD, starting with the shorter COUPLERS. Fasten the Quartz in place using the provided FINIALS, ensure to put on the opposite slices to maintain the balance.

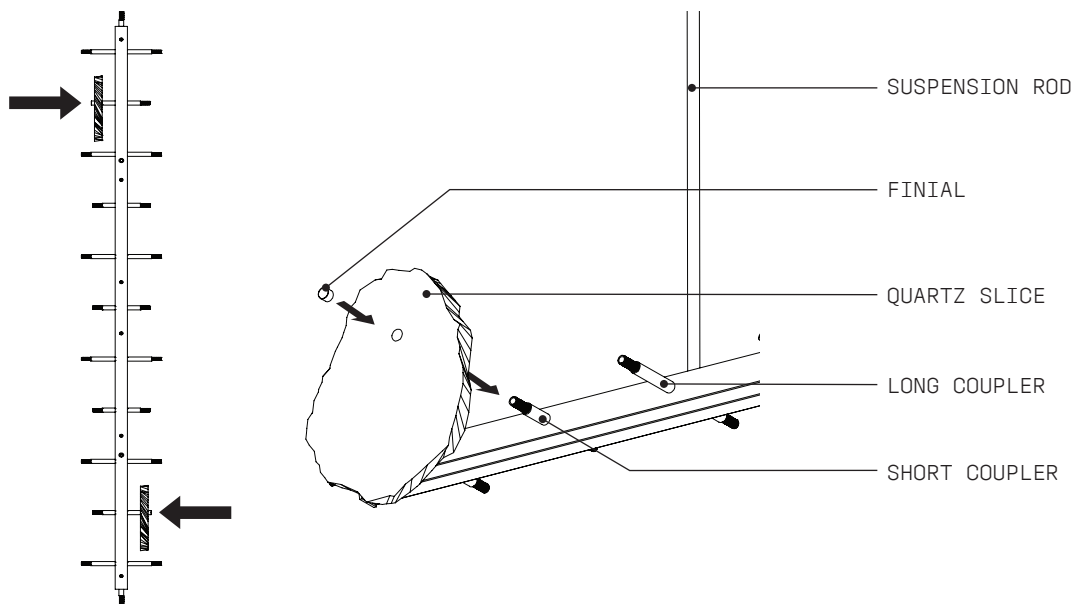

- 5 — Once all the QUARTZ SLICES have been applied to the SHORT COUPLERS, repeat the same method for the LONG COUPLERS, again applying the opposite slices at a time to maintain the balance.

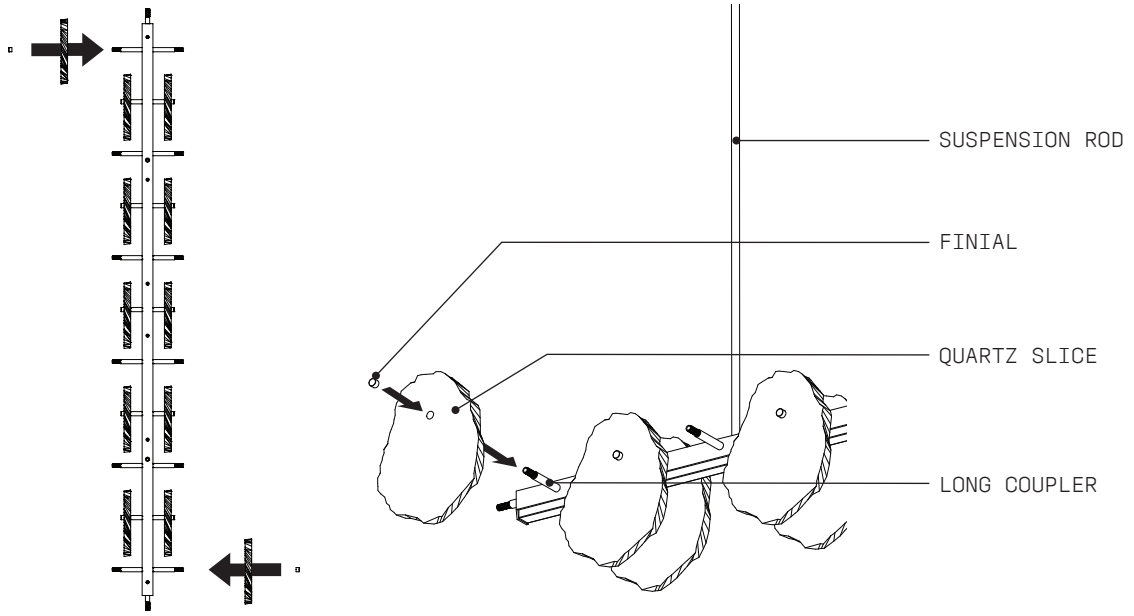

- 6 — Finally attach the remaining 2 QUARTZ SLICES to the ends. Conduct a final visual assessment of PENDANT to ensure all parts have been properly fitted and secured. Once satisfied that everything is in working order, remove all remaining packaging to complete the installation. Please dispose of packaging material responsibly.

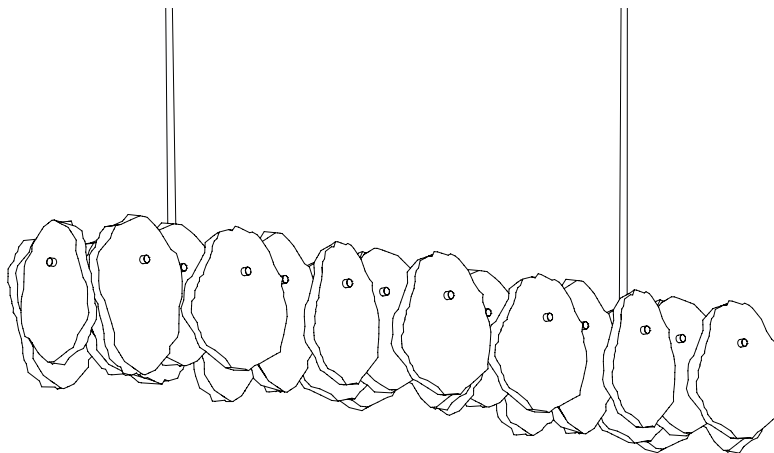

CARE INSTRUCTIONS:

PETRA II is a solid fixture that will require very little maintenance over the years, however changes in appearance of hand applied finishes or unlacquered finishes will vary as these (finshes) are designed to age in appearance. If your PETRA II is treated with care, it will shine brightly for many years to come. We recommend some general tips to help keep it shining its brightest;

Remove dust by simply running an electrostatic duster or dry cloth every few weeks over all exposed surfaces. Under no circumstances should the fixture be cleaned with any type of liquids/detergents or solvents. If more than dusting is required, please contact us at sales@christopherboots.com
We recommend the use of micro fibre cloths.

WARRANTY

1. CHRISTOPHER BOOTS offers a 36 month / 3 year warranty from date of receipt of balance payment on all light fittings supplied (not installation) against mechanical defects.
2. CHRISTOPHER BOOTS will repair or replace defective components or product within this warranty period.
3. Warranty for componentry includes:
4. Led lamps and strips: 3 years / 36 months after receipt.
5. Led drivers 60w: 3 years / 36 months after receipt.
6. Led drivers 100w + 150w: 5 years / 60 months after receipt.
7. Fixtures are labelled clearly with the maximum allowable wattage therefore responsibility of purchaser / end client to ensure correct lamps & wattages are compliant.
8. If unsure, please contact sales@christopherboots.com

CHRISTOPHER BOOTS WILL NOT BE HELD RESPONSIBLE FOR THE FOLLOWING:

1. Damage caused by improper cleaning solutions or methods.
2. Damage caused by improper installation or assembly by customer or customer's agent.
3. Damage caused by improper use of LED:
4. Damage caused by exposure to weather or improper environment – client to check IP rating prior to purchase.
5. Changes in appearance of hand applied finishes or unlacquered finishes.
*Please note that these finishes are designed to age in appearance.
6. Any costs of installation, removal, or re-installation.
7. Restoration, repair work & any parts purchased separately from supplied light fixtures.
8. Damage caused during shipping- all items are packed specifically for global transport.

DAMAGES

1. Damages must be documented and reported within 7 business days of receipt.
2. Photo evidence will be required upon reporting of damage claim.
3. CHRISTOPHER BOOTS is not responsible for repair or replacement of damages reported after this time.
4. If damage has occurred in shipping – all packaging must be retained by receiver. Failure to do so may invalidate any claim.

RETURNS

1. Because of the hand-made nature of our product, we are not able to offer returns.
2. Warranty claims, however will require client to cover shipping enroute back for repair.