

# IRIS SCONCE v2.0

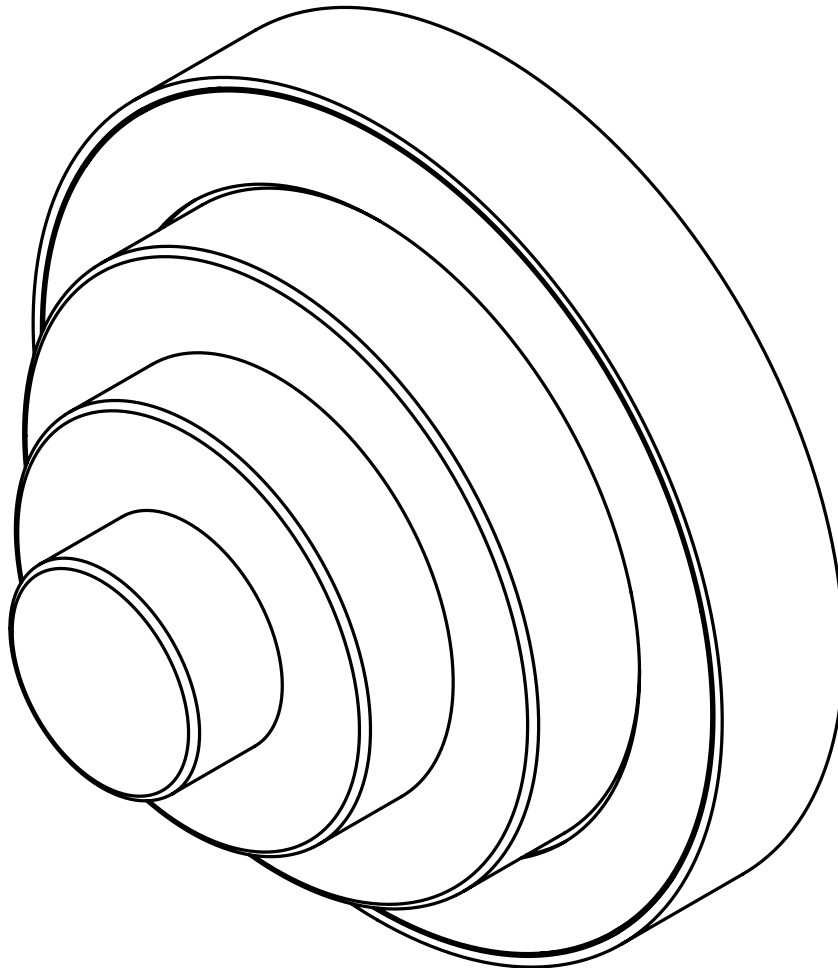

## WARNING

ALL ELECTRICAL CONNECTIONS MUST BE MADE BY A QUALIFIED ELECTRICIAN IN ACCORDANCE WITH THE REGULATIONS AND CODES GOVERNING THE AREA FOR WHICH THE CHRISTOPHER BOOTS FIXTURE IS INTENDED TO BE INSTALLED IN. FAILURE TO DO SO MAY RESULT IN SERIOUS HARM OR DAMAGE TO PROPERTY AND LIFE, AT THE OWNER'S LIABILITY AND EXPENSE. CHRISTOPHER BOOTS WILL NOT BE HELD LIABLE FOR ANY DAMAGE CAUSED FROM INSTALLATION.





**WARNING:  
SHOCK HAZARD**

May result in serious injury or death.  
ENSURE POWER IS OFF before commencing any work.



**WARNING:  
ELECTRICAL**

ALL ELECTRICAL connections must be made by a qualified electrician in accordance with the regulations and codes governing the area for which the CHRISTOPHER BOOTS Fixture is intended to be installed in. Failure to do so may result in serious harm or damage to property and life, at the owner’s liability and expense.

CHRISTOPHER BOOTS will not be held liable for any damage caused from installation.



**WARNING:  
STRUCTURAL**

Ensure that the substrate is securely installed and is in accordance with local building regulations. Failure to do so may potentially result in serious harm or damage of property, at the owner’s liability and expense.

CHRISTOPHER BOOTS will not be held liable for any damage caused from installation.

Refer to supplied WIRING DIAGRAM. →



TECHNICAL INFORMATION									
MODEL	MAX WATTAGE	FIXTURE VOLTAGE (CV)	LAMP TYPE	POWER SUPPLY INPUT VOLTAGE (V AC)	POWER SUPPLY WATTAGE (W)	POWER SUPPLY INPUT CURRENT (typ.)	POWER SUPPLY POWER FACTOR (typ.)	FIXTURE WEIGHT (KG)	EARTH
IRL.MONO.W	3	24	LED STRIP	127 @ 60Hz	60	0.8A/127VAC	PF≥0.97/127VAC	1	YES
				220V @ 60Hz		0.4A/220VAC	PF≥0.95/220VAC		

1 Wearing gloves, unpack the PETRA MONO SCONCE with care ensuring not to scratch the delicate surface of the LIGHT MODULE

2 Carefully unscrew the ALABASTER DIFFUSER in an anti-clockwise direction.

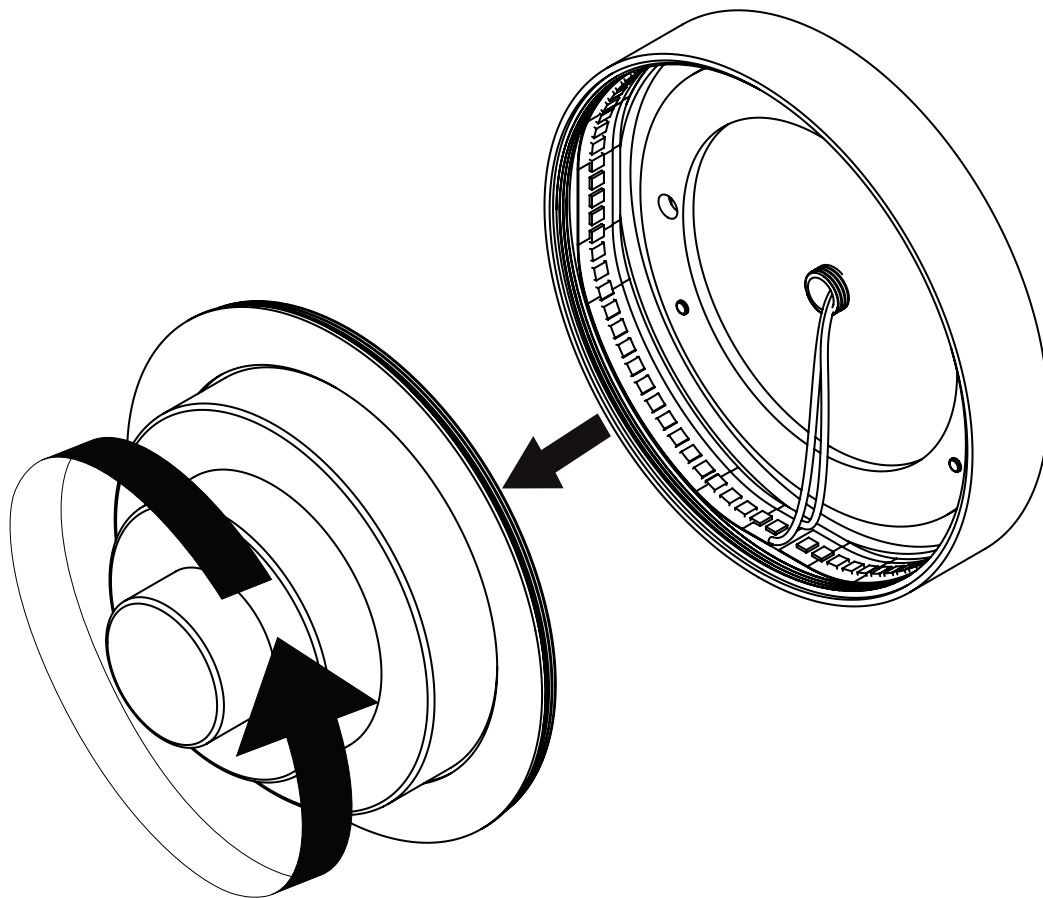

- 3 — Installer to feed power supply into wall opening or remotely locate and prepare 24V DC Power Supply for connection to the Sconce. Refer to supplied WIRING DIAGRAM. →

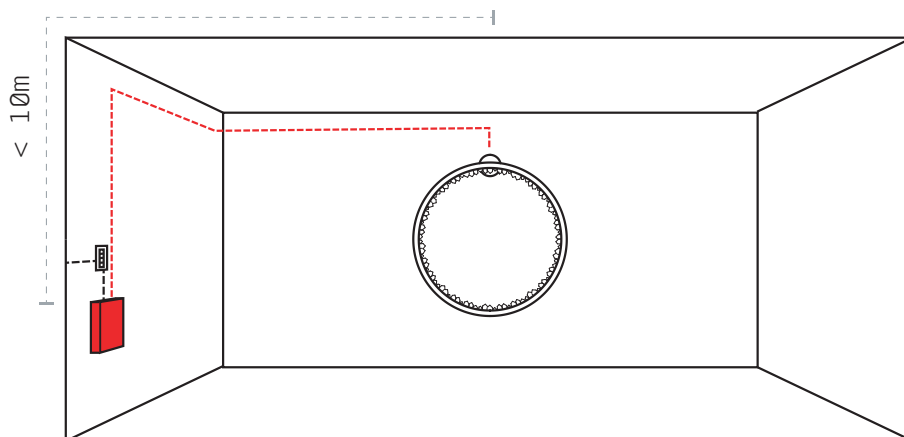

POWER SUPPLY STORED REMOTELY AT SWITCH\*

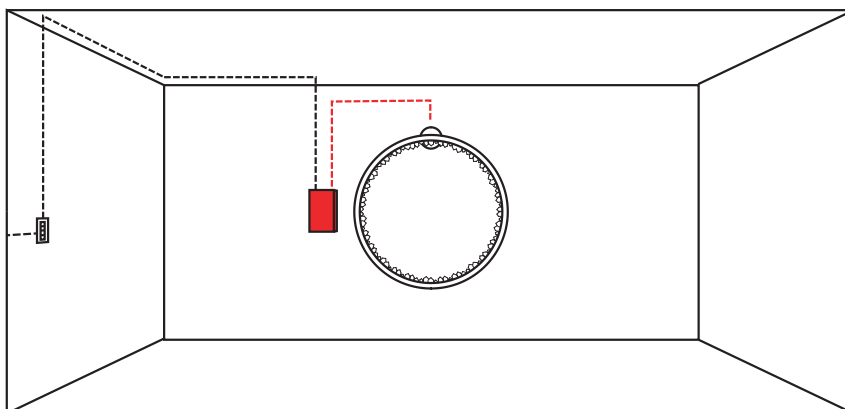

POWER SUPPLY STORED REMOTELY BEHIND LUMINARE\*

- 4 Connect SCONCE POWER CABLE to the 24V DC POWER CABLE.

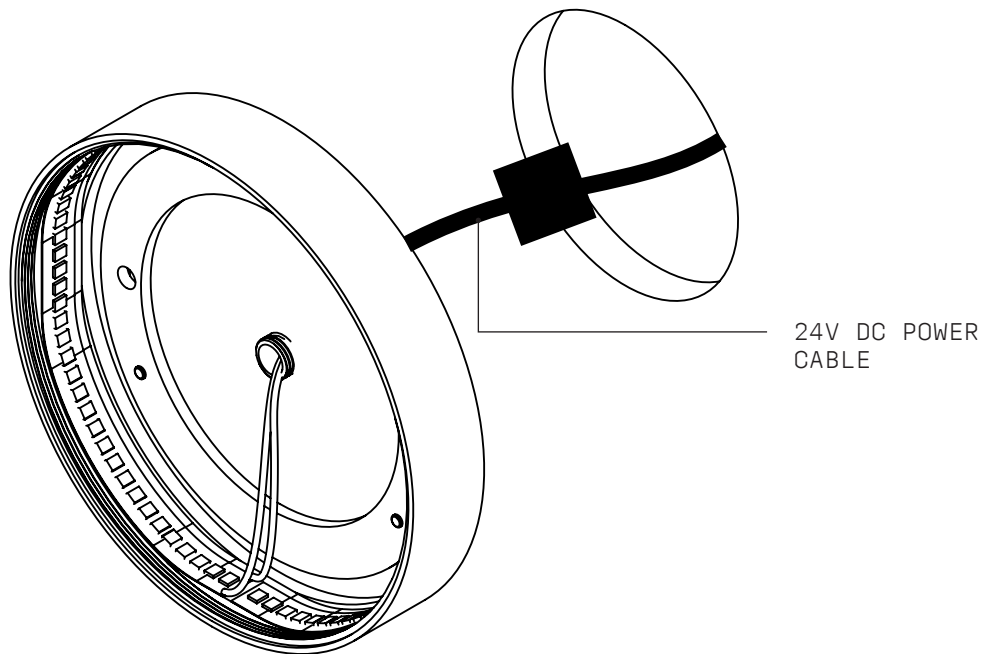

- 5 Attach the IRIS SCONCE to Substrate with appropriate Fasteners.

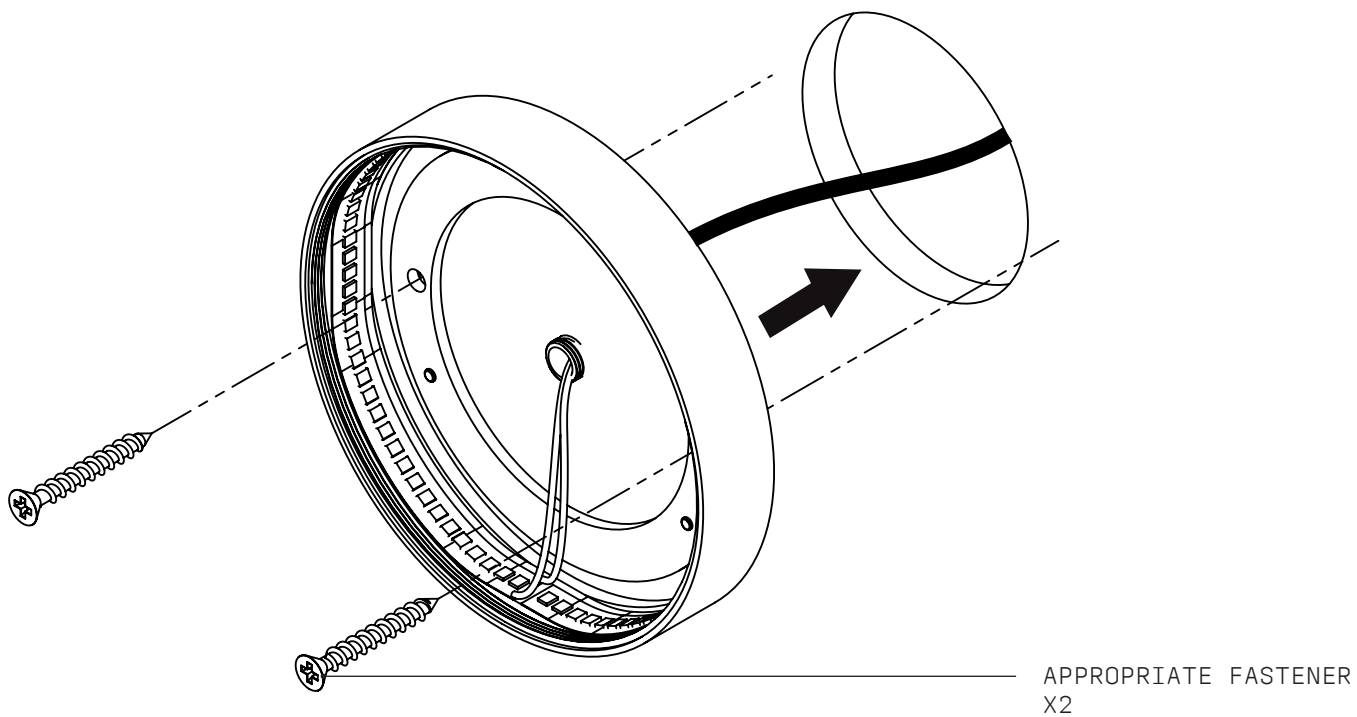

- 6 Carefully replace the ALABASTER DIFFUSER.
- Do not under any circumstances use excessive force as this will damage the delicate brass threads.

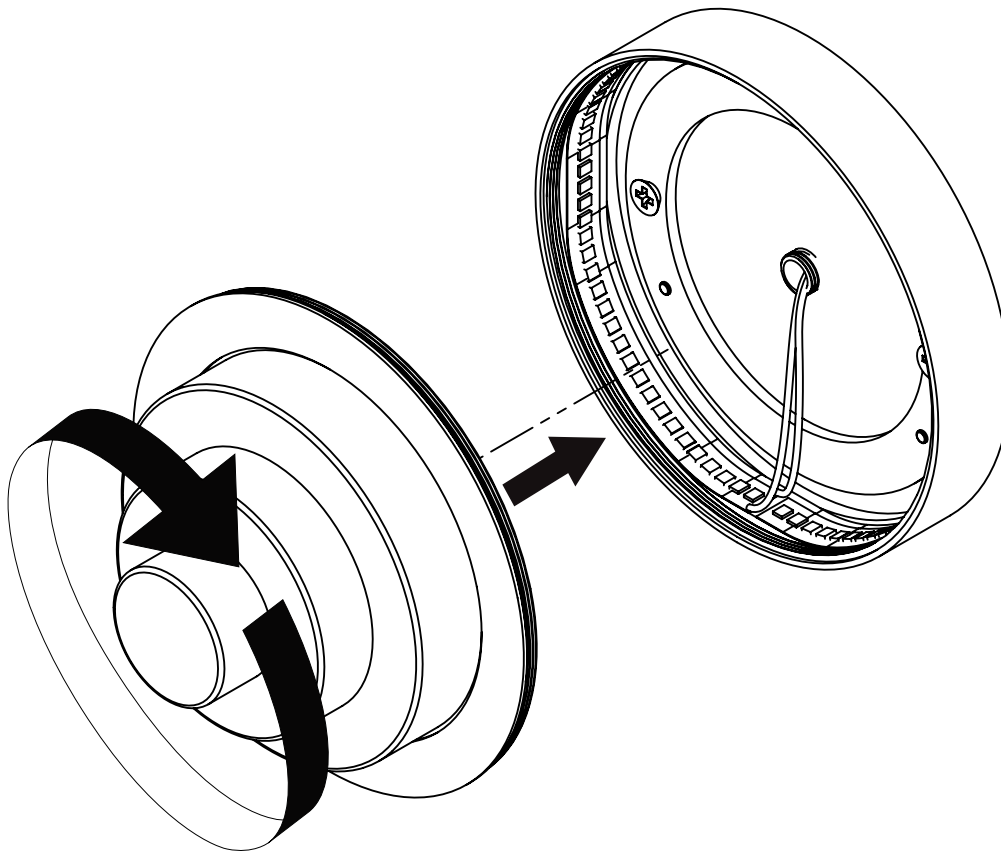

- 7 Conduct a final visual assessment of the fixture to ensure all parts have been properly fitted and secured.

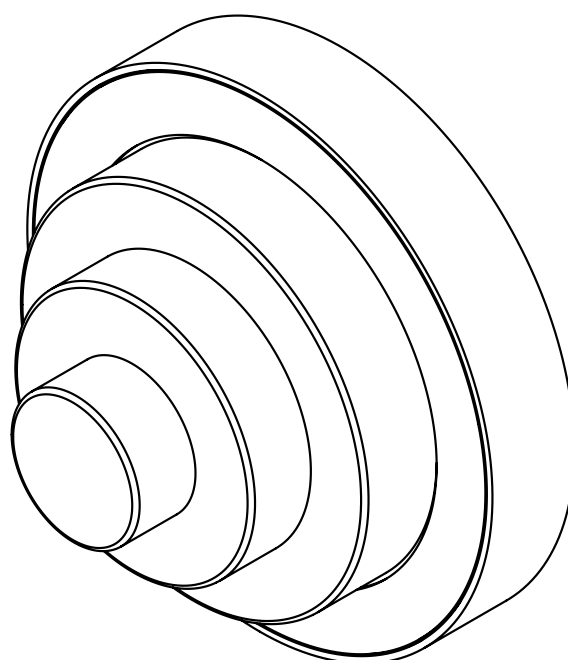

FINISH

## CARE INSTRUCTIONS

- The IRIS SCONCE is for indoor use only (unless otherwise specified) and operable to a maximum ambient temperature of 25° Celsius. The lamping of this luminaire, is a non-user replaceable source and must only be replaced by CHRISTOPHER BOOTS, an appointed agent and/or qualified professional of CHRISTOPHER BOOTS. Should your pendant require relamping, please contact sales@christopherboots.com to make necessary arrangements.
- Remove dust by simply running an electrostatic duster or dry cloth every few weeks over all external surfaces.
- Take particular care when dusting internal surfaces as these are extremely delicate. A clean lint-free cloth will be ample.
- Under no circumstances should the fixture be cleaned with any type of liquids/detergents or solvents.
- We recommend using micro fibre cloths.
- If more than dusting is required, please contact us at: sales@christopherboots.com

## WARRANTY

1. Christopher Boots offers a 36 month / 3 year warranty from date of receipt of balance payment on all light fittings supplied (not installation) against mechanical defects.
2. Christopher Boots will repair or replace defective components or product within this warranty period.
3. Warranty for components includes:
4. LED lamps and strips: 3 years / 36 months after receipt.
5. LED drivers 60w: 3 years / 36 months after receipt.
6. LED drivers 100w + 150w: 5 years / 60 months after receipt.
7. Incandescent lamps: no warranty – no manufacturer warrants filament lamps.
8. Fixtures are clearly labeled with maximum allowable wattage therefore responsibility of installer / end client to ensure correct lamps & wattages are compliant.
9. Use of higher wattage bulbs than indicated will forfeit warranty.
10. Warranty claims require client to cover shipping enroute back for repair.
11. Any questions? Contact sales@christopherboots.com

## CHRISTOPHER BOOTS WILL NOT BE HELD RESPONSIBLE FOR THE FOLLOWING

1. Damage caused by improper cleaning solutions or methods.
2. Damage caused by improper installation or assembly by customer or customer's agent.
3. Damage caused by improper use of light bulbs.
4. Where applicable, installers ensure screwing lamps / glass lamp cover inline with trajectory of product branch + lampholder upon lamp replacement.
5. Where applicable, a screwing motion of slightest angle may cause cross-threading & breakage not covered under warranty.
6. Damage caused by exposure to weather or improper environment – client to check IP rating prior to purchase.
7. Changes in appearance of hand applied finishes or unlacquered finishes.
8. Please note that finishes are designed to age in appearance.
9. Any costs of installation, removal, or re-installation.
10. Restoration, repair work & any parts purchased separately from supplied light fixtures.
11. Damage caused during shipping. All items are packed specifically for global transport.

## DAMAGES

1. Damages must be documented and reported within 7 business days of receipt.
2. If external flexible cable of this luminaire is damaged, it shall be exclusively replaced by the manufacturer or your service agent in order to avoid hazard.
3. Photo evidence will be required upon reporting of damage claim.
4. Christopher Boots is not responsible for repair or replacement of damages reported after this time.
5. If damage has occurred in shipping, all packaging must be retained by receiver. Failure to do so may invalidate any claim.

## RETURNS

1. Because of the hand-made nature of our product, we unable to offer returns.