

FRANK Barstool

DESIGN BY OKHA

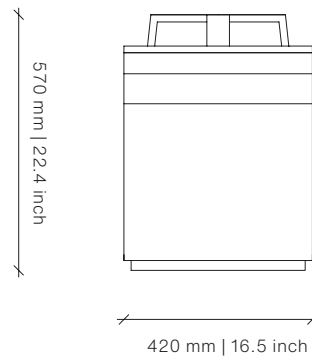

Frame

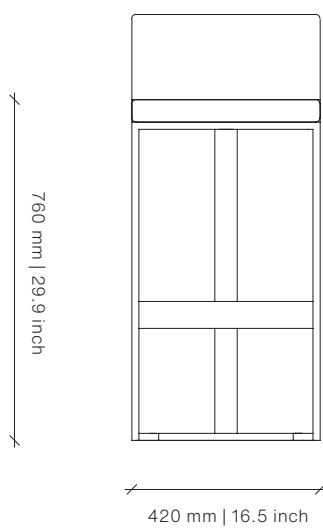
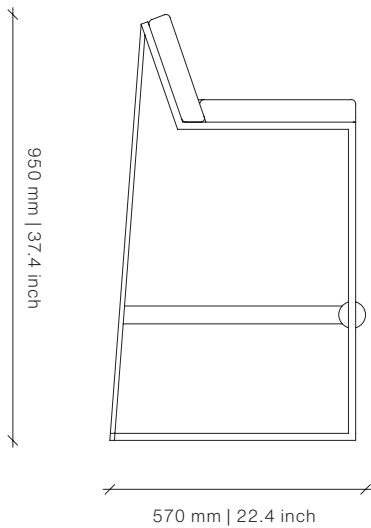

Black
Ferrograin



Saddlewood
Ferrograin



Light Grey
Ferrograin

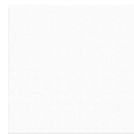

White
Ferrograin

Dimensions (mm)

420W x 570D x 950H
Seat Height: 760

Dimensions (inches)

16.5W x 22.4D x 37.4H
Seat Height: 29.9

COM 1.2 m | 1.3 yd

COL 2.2 m² | 23.3 sq ft

Different textures, grains, colouration and densities are all natural characteristics of timbers. We find these variances an inherent and valuable part of the natural beauty of wood, no two pieces are the same making each OKHA design a unique, characterful piece and each product will be different from the next. Timber movement will also occur as this is a natural product.

STONE: Marble is a beautiful natural material with inherent imperfections in its structure, veining and coloration. As such, some slabs may be reinforced with meshing on the underside and may have colour matched resin fills in minor cracks and surface blemishes. Please note that this is standard practice.

METAL: All metals will go through a process of natural aging and oxidization due to environmental conditions. The result of this aging process will bring about colour change, to slow and reduce this natural process, appropriate cleaning and maintenance products can be used.

twentieth

sales@twentieth.net
323.904.1200
www.twentieth.net

OKHA

FRANK Counterstool

DESIGN BY OKHA

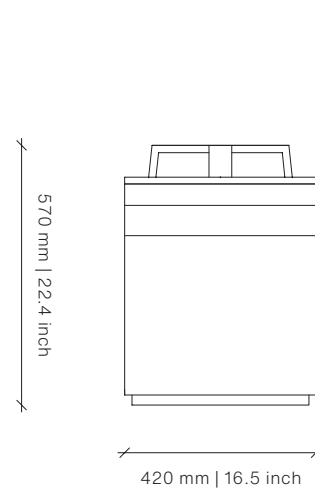
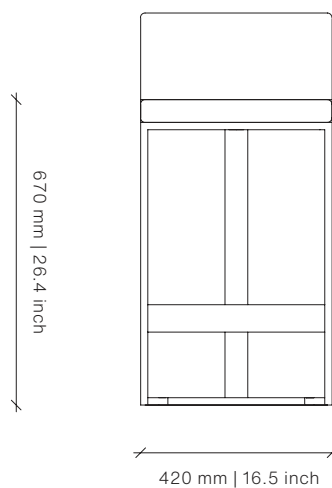
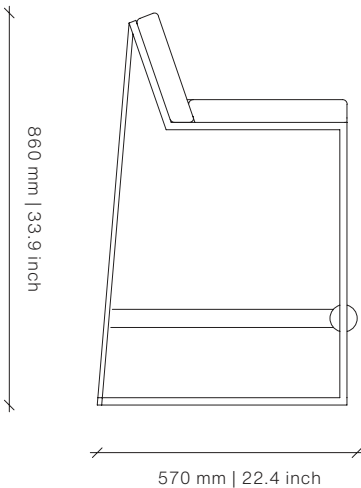

Frame

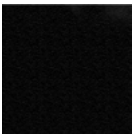

Black
Ferrograin



Saddlewood
Ferrograin



Light Grey
Ferrograin

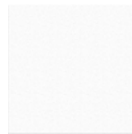

White
Ferrograin

Dimensions (mm)

420W x 570D x 860H
Seat Height: 670

Dimensions (inches)

16.5W x 22.4D x 33.9H
Seat Height: 26.4

COM 1.2 m | 1.3 yd

COL 2.2 m² | 23.3 sq ft

Different textures, grains, colouration and densities are all natural characteristics of timbers. We find these variances an inherent and valuable part of the natural beauty of wood, no two pieces are the same making each OKHA design a unique, characterful piece and each product will be different from the next. Timber movement will also occur as this is a natural product.

STONE: Marble is a beautiful natural material with inherent imperfections in its structure, veining and coloration. As such, some slabs may be reinforced with meshing on the underside and may have colour matched resin fills in minor cracks and surface blemishes. Please note that this is standard practice.

METAL: All metals will go through a process of natural aging and oxidization due to environmental conditions. The result of this aging process will bring about colour change, to slow and reduce this natural process, appropriate cleaning and maintenance products can be used.

twentieth

sales@twentieth.net
323.904.1200
www.twentieth.net

OKHA

FRANK GOLD Barstool

DESIGN BY OKHA

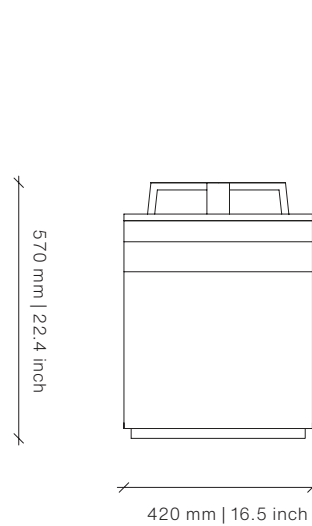
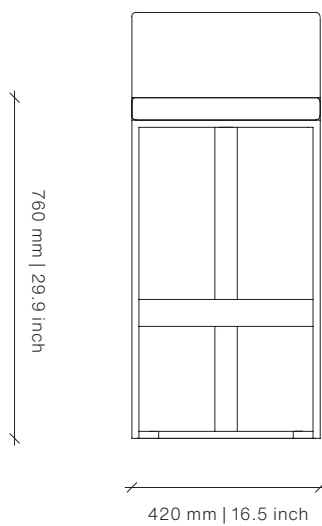
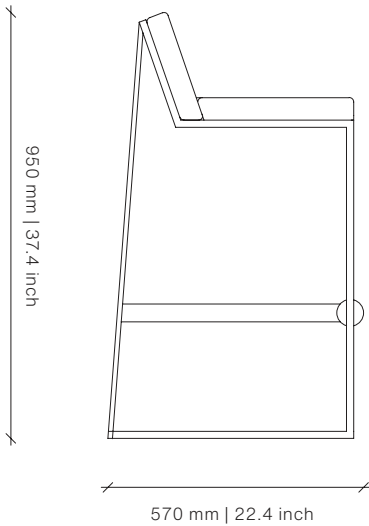

Frame

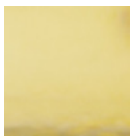

Gold
Lacquer

Dimensions (mm)

420W x 570D x 950H
Seat Height: 760

Dimensions (inches)

16.5W x 22.4D x 37.4H
Seat Height: 29.9

COM 1.2 m | 1.3 yd

COL 2.2 m² | 23.3 sq ft

Different textures, grains, colouration and densities are all natural characteristics of timbers. We find these variances an inherent and valuable part of the natural beauty of wood, no two pieces are the same making each OKHA design a unique, characterful piece and each product will be different from the next. Timber movement will also occur as this is a natural product.

STONE: Marble is a beautiful natural material with inherent imperfections in its structure, veining and coloration. As such, some slabs may be reinforced with meshing on the underside and may have colour matched resin fills in minor cracks and surface blemishes. Please note that this is standard practice.

METAL: All metals will go through a process of natural aging and oxidization due to environmental conditions. The result of this aging process will bring about colour change, to slow and reduce this natural process, appropriate cleaning and maintenance products can be used.

twentieth

sales@twentieth.net
323.904.1200
www.twentieth.net

OKHA

FRANK GOLD Counterstool

DESIGN BY OKHA

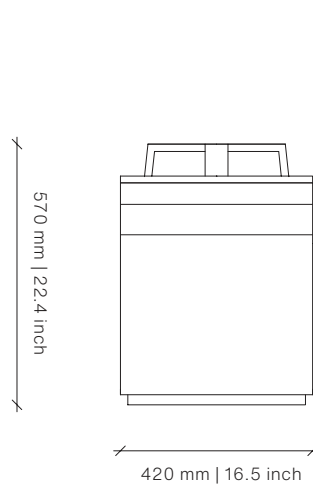
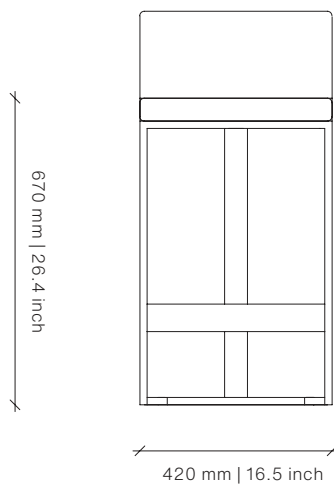
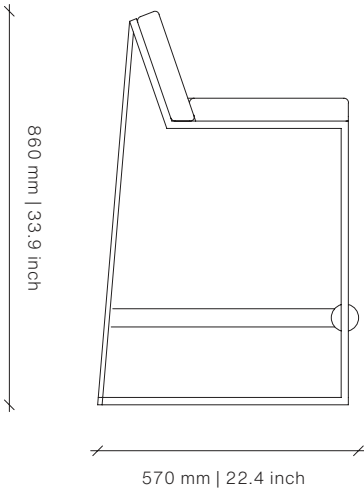

Frame



Gold
Lacquer

Dimensions (mm)

420W x 570D x 860H
Seat Height: 670

Dimensions (inches)

16.5W x 22.4D x 33.9H
Seat Height: 26.4

COM 1.2 m | 1.3 yd

COL 2.2 m² | 23.3 sq ft

Different textures, grains, colouration and densities are all natural characteristics of timbers. We find these variances an inherent and valuable part of the natural beauty of wood, no two pieces are the same making each OKHA design a unique, characterful piece and each product will be different from the next. Timber movement will also occur as this is a natural product.
STONE: Marble is a beautiful natural material with inherent imperfections in its structure, veining and coloration. As such, some slabs may be reinforced with meshing on the underside and may have colour matched resin fills in minor cracks and surface blemishes. Please note that this is standard practice.
METAL: All metals will go through a process of natural aging and oxidization due to environmental conditions. The result of this aging process will bring about colour change, to slow and reduce this natural process, appropriate cleaning and maintenance products can be used.

twentieth

sales@twentieth.net
323.904.1200
www.twentieth.net

OKHA