

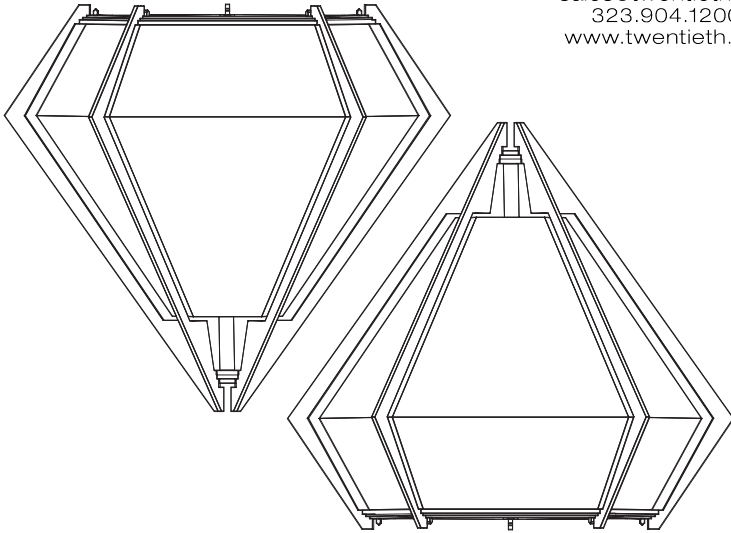

FILE#: E356487

twentieth

sales@twentieth.net  
323.904.1200  
www.twentieth.net



# HARLOW SCONCE

## Installation Guide

- Certified electrician recommended for electrical installation.
- Terminal Block not included. Installation may require advice from a qualified person.
- For all LED fixtures, use only with class 2 power unit.
- The light source contained in this luminaire shall only be replaced by the manufacturer or his service agent or a similar qualified person.

**\*IMPORTANT: Please provide email confirmation that your order and its related components have been received in their entirety and in good condition. Failure to do so within 7 days of delivery will waive all product warranties.**

GABRIEL SCOTT

EST 2012

**Provided Supplies:**

- Harlow Sconce fixture
- Universal T-bar
- Installation Screws
- LED Driver
- Spare LED chip

**Required Tools:**

- Screwdriver
- 4x 2-pole Wiring Terminals, screw or screwless, 12-18AWG (1.0-2.5mm<sup>2</sup>), rated for 600V, 15A - EX: WAGO 222-412
- Requires LED driver; Input: Local Line Voltage, Output 12Vdc SELV, 5A, Max 60 Watt, Class 2 LED Driver.

**STEP  
1**

Shut-down associated electrical breaker and wire LED driver to power source. Then secure driver in junction box using provided universal T-bar.

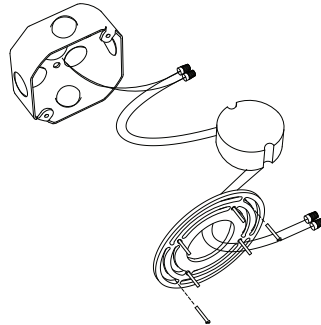

**STEP  
2**

Remove the glass retainer by unscrewing both screws as shown below.

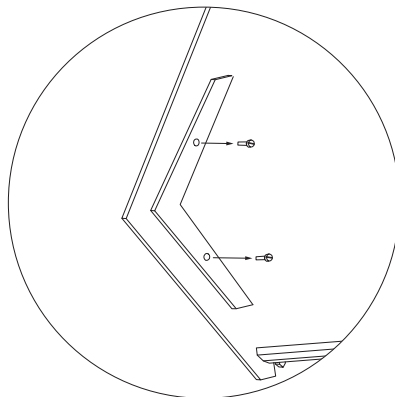

twentieth

sales@twentieth.net  
323.904.1200  
www.twentieth.net

**STEP**  
**3**

Remove the light bulb assembly from the fixture.

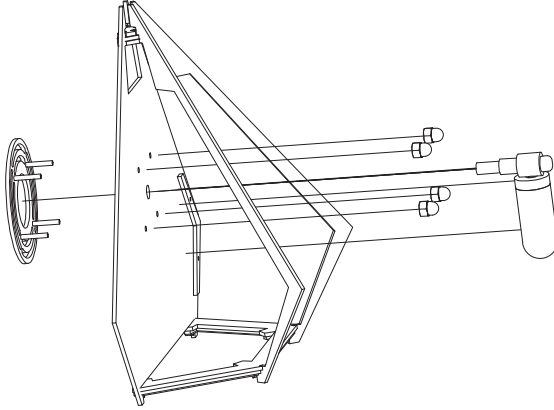

**STEP**  
**4**

Slide the glass into the fixture and screw the glass retainer back in its place.

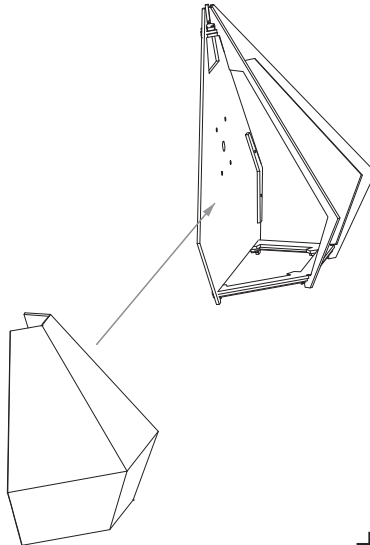

twentieth

sales@twentieth.net  
323.904.1200  
www.twentieth.net

**STEP**  
**5**

Once the glass is installed, reinstall the bulb assembly through the opening at the bottom of the fixture.

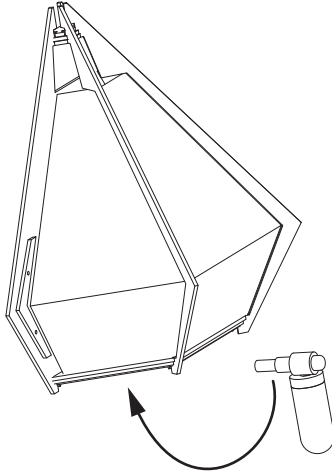

**STEP**  
**6**

Once steps 1 thru 4 are complete, instal the light fixture on to the junction box by threading the four supplied nuts on to the T-bar.

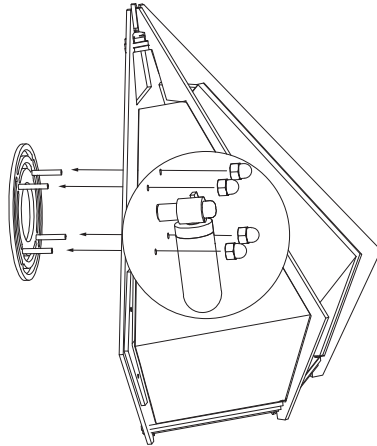

twentieth

sales@twentieth.net  
323.904.1200  
www.twentieth.net